

Project Name: \_\_\_\_\_  
 Job #: \_\_\_\_\_

## REDUCING TEES

### ASME B16.9 & ASTM A234 WPB

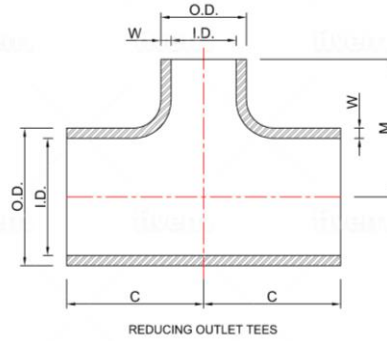

Source:  Import  Domestic  Approved

## DIMENSIONS

UOM: Inches/LBS

PIPE SIZE	DIMENSIONS OF RUN				DIMENSIONS OF BRANCH				PIPE SCHEDULE (STD)	APPROX WEIGHT
	OUTSIDE DIAMETER (O.D.)	INSIDE DIAMETER (I.D.)	WALL THICKNESS (W)	CENTER TO END (C)	OUTSIDE DIAMETER (O.D.)	INSIDE DIAMETER (I.D.)	WALL THICKNESS (W)	CENTER TO END (C)		
¾ x ½	1.05	0.824	0.113	1.12	0.84	0.622	0.109	1.12	40	0.41
1 x ¾	1.32	1.049	0.133	1.50	1.05	0.824	0.113	1.50	40	0.81
1 x ½	1.32	1.049	0.133	1.50	0.84	0.622	0.109	1.50	40	0.78
1 ¼ x 1	1.66	1.380	0.140	1.88	1.32	1.049	0.133	1.88	40	1.30
1 ¼ x ¾	1.66	1.380	0.140	1.88	1.05	0.824	0.113	1.88	40	1.30
1 ¼ x ½	1.66	1.380	0.140	1.88	0.84	0.622	0.109	1.88	40	1.30
1 ½ x 1 ¼	1.90	1.610	0.145	2.25	1.66	1.380	0.140	2.25	40	2.00
1 ½ x 1	1.90	1.610	0.145	2.25	1.32	1.049	0.133	2.25	40	1.90
1 ½ x ¾	1.90	1.610	0.145	2.25	1.05	0.824	0.113	2.25	40	1.80
1 ½ x ½	1.90	1.610	0.145	2.25	0.84	0.622	0.109	2.25	40	1.80
2 x 1 ½	2.38	2.067	0.154	2.50	1.90	1.610	0.145	2.38	40	3.10
2 x 1 ¼	2.38	2.067	0.154	2.50	1.66	1.380	0.140	2.25	40	3.00
2 x 1	2.38	2.067	0.154	2.50	1.32	1.049	0.133	2.00	40	2.80
2 x ¾	2.38	2.067	0.154	2.50	1.05	0.824	0.113	1.75	40	2.50
2 ½ x 2	2.88	2.469	0.203	3.00	2.38	2.067	0.154	2.75	40	5.40
2 ½ x 1 ½	2.88	2.469	0.203	3.00	1.90	1.610	0.145	2.62	40	5.10
2 ½ x 1 ¼	2.88	2.469	0.203	3.00	1.66	1.380	0.140	2.50	40	4.80
2 ½ x 1	2.88	2.469	0.203	3.00	1.32	1.049	0.133	2.25	40	4.60
3 x 2 ½	3.50	3.068	0.216	3.38	2.88	2.469	0.203	3.25	40	7.20
3 x 2	3.50	3.068	0.216	3.38	2.38	2.067	0.154	3.00	40	7.00
3 x 1 ½	3.50	3.068	0.216	3.38	1.90	1.610	0.145	2.88	40	6.80
3 x 1 ¼	3.50	3.068	0.216	3.38	1.66	1.380	0.140	2.75	40	6.60
3 x 1	3.50	3.068	0.216	3.38	1.32	1.049	0.133	2.62	40	6.50

FITTINGS T RED

Project Name: \_\_\_\_\_

Job #: \_\_\_\_\_

FITTINGS T RED

PIPE SIZE	DIMENSIONS OF RUN				DIMENSIONS OF BRANCH				PIPE SCHEDULE (STD)	APPROX WEIGHT
	OUTSIDE DIAMETER (O.D.)	INSIDE DIAMETER (I.D.)	WALL THICKNESS (W)	CENTER TO END (C)	OUTSIDE DIAMETER (O.D.)	INSIDE DIAMETER (I.D.)	WALL THICKNESS (W)	CENTER TO END (C)		
3 ½ x 3	4.00	3.548	0.226	3.75	3.50	3.068	0.216	3.62	40	9.80
3 ½ x 2 ½	4.00	3.548	0.226	3.75	2.88	2.474	0.203	3.50	40	9.40
3 ½ x 2	4.00	3.548	0.226	3.75	2.38	2.072	0.154	3.25	40	9.20
3 ½ x 1 ½	4.00	3.548	0.226	3.75	1.90	1.610	0.145	3.12	40	8.90
4 x 3 ½	4.50	4.026	0.237	4.12	4.00	3.548	0.226	4.00	40	11.90
4 x 3	4.50	4.026	0.237	4.12	3.50	3.068	0.216	3.88	40	11.60
4 x 2 ½	4.50	4.026	0.237	4.12	2.88	2.469	0.203	3.75	40	11.40
4 x 2	4.50	4.026	0.237	4.12	2.38	2.067	0.154	3.50	40	11.20
4 x 1 ½	4.50	4.026	0.237	4.12	1.90	1.610	0.145	3.38	40	11.20
5 x 4	5.56	5.047	0.258	4.88	4.50	4.026	0.237	4.62	40	20.50
5 x 3 ½	5.56	5.047	0.258	4.88	4.00	3.548	0.226	4.50	40	20.00
5 x 3	5.56	5.047	0.258	4.88	3.50	3.068	0.216	4.38	40	19.40
5 x 2 ½	5.56	5.047	0.258	4.88	2.88	2.469	0.203	4.25	40	19.00
5 x 2	5.56	5.047	0.258	4.88	2.38	2.067	0.154	4.12	40	18.80
6 x 5	6.62	6.065	0.280	5.62	5.56	5.047	0.258	5.38	40	32.00
6 x 4	6.62	6.065	0.280	5.62	4.50	4.026	0.237	5.12	40	30.50
6 x 3 ½	6.62	6.065	0.280	5.62	4.00	3.548	0.226	5.00	40	30.00
6 x 3	6.62	6.065	0.280	5.62	3.50	3.068	0.216	4.88	40	30.00
6 x 2 ½	6.62	6.065	0.280	5.62	2.88	2.469	0.203	4.75	40	29.70
6 x 2	6.62	6.065	0.280	5.62	2.38	2.067	0.154	4.75	40	29.00
8 x 6	8.62	7.981	0.322	7.00	6.62	6.065	0.280	6.62	40	56.50
8 x 5	8.62	7.981	0.322	7.00	5.56	5.047	0.258	6.38	40	54.00
8 x 4	8.62	7.981	0.322	7.00	4.50	4.026	0.237	6.12	40	53.20
8 x 3 ½	8.62	7.981	0.322	7.00	4.00	3.548	0.226	6.00	40	53.00
8 x 3	8.62	7.981	0.322	7.00	3.50	3.068	0.216	6.00	40	52.00
10 x 8	10.75	10.020	0.365	8.50	8.62	7.981	0.322	8.00	40	86.50
10 x 6	10.75	10.020	0.365	8.50	6.62	6.060	0.280	7.62	40	85.90
10 x 5	10.75	10.020	0.365	8.50	5.56	5.047	0.258	7.50	40	82.50
10 x 4	10.75	10.020	0.365	8.50	4.50	4.026	0.237	7.25	40	82.00
10 x 3	10.75	10.020	0.365	8.50	3.50	3.068	0.216	7.25	40	79.00
12 x 10	12.75	12.000	0.375	10.00	10.75	10.020	0.365	9.50	-	123.00
12 x 8	12.75	12.000	0.375	10.00	8.62	7.981	0.322	9.00	-	120.00
12 x 6	12.75	12.000	0.375	10.00	6.62	6.060	0.280	8.62	-	118.00
12 x 5	12.75	12.000	0.375	10.00	5.56	5.047	0.258	8.50	-	117.00
12 x 4	12.75	12.000	0.375	10.00	4.50	4.026	0.237	8.50	-	112.00
14 x 12	14.00	13.250	0.375	11.00	12.75	12.000	0.375	10.62	-	151.00
14 x 10	14.00	13.250	0.375	11.00	10.75	10.020	0.365	10.12	-	148.00
14 x 8	14.00	13.250	0.375	11.00	8.62	7.981	0.322	9.75	-	146.00
14 x 6	14.00	13.250	0.375	11.00	6.62	6.065	0.280	9.38	-	145.00
16 x 14	16.00	15.250	0.375	12.00	14.00	13.250	0.375	12.00	-	221.00
16 x 12	16.00	15.250	0.375	12.00	12.75	12.000	0.375	11.62	-	213.00
16 x 10	16.00	15.250	0.375	12.00	10.75	10.020	0.364	11.12	-	197.00
16 x 8	16.00	15.250	0.375	12.00	8.62	7.981	0.322	10.75	-	190.00
16 x 6	16.00	15.250	0.375	12.00	6.62	6.060	0.280	10.38	-	180.00



Project Name: \_\_\_\_\_

Job #: \_\_\_\_\_

PIPE SIZE	DIMENSIONS OF RUN				DIMENSIONS OF BRANCH				PIPE SCHEDULE (STD)	APPROX WEIGHT
	OUTSIDE DIAMETER (O.D.)	INSIDE DIAMETER (I.D.)	WALL THICKNESS (W)	CENTER TO END (C)	OUTSIDE DIAMETER (O.D.)	INSIDE DIAMETER (I.D.)	WALL THICKNESS (W)	CENTER TO END (C)		
18 x 16	18.00	17.250	0.375	13.50	16.00	15.250	0.375	13.00	-	262.00
18 x 14	18.00	17.250	0.375	13.50	14.00	13.250	0.375	13.00	-	248.00
18 x 12	18.00	17.250	0.375	13.50	12.75	12.000	0.375	12.62	-	241.00
18 x 10	18.00	17.250	0.375	13.50	10.75	10.020	0.365	12.12	-	229.00
18 x 8	18.00	17.250	0.375	13.50	8.62	7.981	0.322	11.75	-	216.00
20 x 18	20.00	19.250	0.375	15.00	18.00	17.250	0.375	14.50	-	352.00
20 x 16	20.00	19.250	0.375	15.00	16.00	15.250	0.375	14.00	-	339.00
20 x 14	20.00	19.250	0.375	15.00	14.00	13.250	0.375	14.00	-	327.00
20 x 12	20.00	19.250	0.375	15.00	12.75	12.000	0.375	13.62	-	315.00
20 x 10	20.00	19.250	0.375	15.00	10.75	10.020	0.365	13.12	-	305.00
20 x 8	20.00	19.250	0.375	15.00	8.62	7.976	0.322	12.75	-	293.00
24 x 20	24.00	23.250	0.375	17.00	20.00	19.250	0.375	17.00	-	500.00
24 x 18	24.00	23.250	0.375	17.00	18.00	17.250	0.375	16.50	-	487.00
24 x 16	24.00	23.250	0.375	17.00	16.00	15.250	0.375	16.00	-	475.00
24 x 14	24.00	23.250	0.375	17.00	14.00	13.250	0.375	16.00	-	465.00
24 x 12	24.00	23.250	0.375	17.00	12.75	12.000	0.375	15.62	-	450.00
24 x 10	24.00	23.250	0.375	17.00	10.75	10.020	0.365	15.12	-	447.00
30 x 24	30.00	29.250	0.375	22.00	24.00	23.250	0.375	21.00	-	795.00
30 x 20	30.00	29.250	0.375	22.00	20.00	19.250	0.375	20.00	-	749.00
30 x 18	30.00	29.250	0.375	22.00	18.00	17.250	0.375	19.50	-	727.00
30 x 16	30.00	29.250	0.375	22.00	16.00	15.250	0.375	19.00	-	715.00
36 x 30	36.00	35.250	0.375	26.50	30.00	29.250	0.375	25.00	-	1207.00
36 x 24	36.00	35.250	0.375	26.50	24.00	23.250	0.375	24.00	-	1129.00
36 x 20	36.00	35.250	0.375	26.50	20.00	19.250	0.375	23.00	-	1072.00
36 x 18	36.00	35.250	0.375	26.50	18.00	17.250	0.375	22.50	-	1136.00
42 x 36	42.00	41.250	0.375	30.00	36.00	35.250	0.375	28.00	-	1415.00
42 x 30	42.00	41.250	0.375	30.00	30.00	29.250	0.375	28.00	-	1327.00
42 x 24	42.00	41.250	0.375	30.00	24.00	23.250	0.375	26.00	-	1248.00
42 x 20	42.00	41.250	0.375	30.00	20.00	19.250	0.375	26.00	-	1200.00
48 x 42	48.00	47.250	0.375	35.00	42.00	41.250	0.375	32.00	-	2207.00
48 x 36	48.00	47.250	0.375	35.00	36.00	35.250	0.375	31.00	-	2127.00
48 x 30	48.00	47.250	0.375	35.00	30.00	29.250	0.375	30.00	-	2048.00
48 x 24	48.00	47.250	0.375	35.00	24.00	23.250	0.375	29.00	-	1900.00

FITTINGS T RED

acecarbonsteel.com



Project Name: \_\_\_\_\_

Job #: \_\_\_\_\_

## REDUCING TEES

ASME B16.9 & ASTM A234 WPB

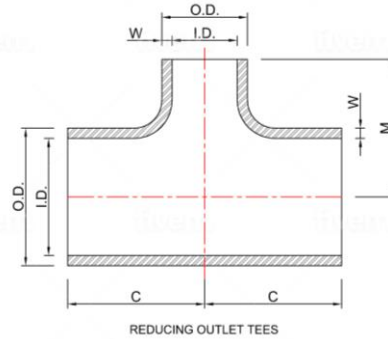

Source:  Import  Domestic  Approved

### DIMENSIONS

UOM: Inches/LBS

PIPE SIZE	DIMENSIONS OF RUN				DIMENSIONS OF BRANCH				PIPE SCHEDULE (XS)	APPROX WEIGHT
	OUTSIDE DIAMETER (O.D.)	INSIDE DIAMETER (I.D.)	WALL THICKNESS (W)	CENTER TO END (C)	OUTSIDE DIAMETER (O.D.)	INSIDE DIAMETER (I.D.)	WALL THICKNESS (W)	CENTER TO END (C)		
¾ x ½	1.05	0.742	0.154	1.12	0.84	0.546	0.147	1.12	80	0.47
1 x ¾	1.32	0.957	0.179	1.50	1.05	0.742	0.154	1.50	80	0.98
1 x ½	1.32	0.957	0.179	1.50	0.84	0.546	0.147	1.50	80	0.92
1 ¼ x 1	1.66	1.278	0.191	1.88	1.32	0.957	0.179	1.88	80	1.60
1 ¼ x ¾	1.66	1.278	0.191	1.88	1.05	0.742	0.154	1.88	80	1.60
1 ¼ x ½	1.66	1.278	0.191	1.88	0.84	0.546	0.147	1.88	80	1.60
1 ½ x 1 ¼	1.90	1.500	0.200	2.25	1.66	1.278	0.191	2.25	80	2.40
1 ½ x 1	1.90	1.500	0.200	2.25	1.32	0.957	0.179	2.25	80	2.30
1 ½ x ¾	1.90	1.500	0.200	2.25	1.05	0.742	0.154	2.25	80	2.20
1 ½ x ½	1.90	1.500	0.200	2.25	0.84	0.546	0.147	2.25	80	2.20
2 x 1 ½	2.38	1.944	0.218	2.50	1.90	1.500	0.200	2.38	80	3.80
2 x 1 ¼	2.38	1.944	0.218	2.50	1.66	1.278	0.191	2.25	80	3.70
2 x 1	2.38	1.944	0.218	2.50	1.32	0.957	0.179	2.00	80	3.50
2 x ¾	2.38	1.944	0.218	2.50	1.05	0.742	0.154	1.75	80	3.50
2 ½ x 2	2.88	2.323	0.276	3.00	2.38	1.944	0.218	2.75	80	6.30
2 ½ x 1 ½	2.88	2.323	0.276	3.00	1.90	1.500	0.200	2.62	80	6.20
2 ½ x 1 ¼	2.88	2.323	0.276	3.00	1.66	1.278	0.191	2.50	80	6.00
2 ½ x 1	2.88	2.323	0.276	3.00	1.32	0.957	0.179	2.25	80	5.80
3 x 2 ½	3.50	2.900	0.300	3.38	2.88	2.323	0.276	3.25	80	8.80
3 x 2	3.50	2.900	0.300	3.38	2.38	1.939	0.218	3.00	80	8.60
3 x 1 ½	3.50	2.900	0.300	3.38	1.90	1.500	0.200	2.88	80	8.10
3 x 1 ¼	3.50	2.900	0.300	3.38	1.66	1.278	0.191	2.75	80	8.00
3 x 1	3.50	2.900	0.300	3.38	1.32	0.957	0.179	2.62	80	7.80

FITTINGS T RED

Project Name: \_\_\_\_\_

Job #: \_\_\_\_\_

PIPE SIZE	DIMENSIONS OF RUN				DIMENSIONS OF BRANCH				PIPE SCHEDULE (XS)	APPROX WEIGHT
	OUTSIDE DIAMETER (O.D.)	INSIDE DIAMETER (I.D.)	WALL THICKNESS (W)	CENTER TO END (C)	OUTSIDE DIAMETER (O.D.)	INSIDE DIAMETER (I.D.)	WALL THICKNESS (W)	CENTER TO END (C)		
3 ½ x 3	4.00	3.364	0318	3.75	3.50	2.900	0.300	3.62	80	12.60
3 ½ x 2 ½	4.00	3.364	0318	3.75	2.88	2.323	0.276	3.50	80	12.10
3 ½ x 2	4.00	3.364	0318	3.75	2.38	1.939	0.218	3.25	80	11.70
3 ½ x 1 ½	4.00	3.364	0318	3.75	1.90	1.500	0.200	3.12	80	11.60
4 x 3 ½	4.50	3.826	0.337	4.12	4.00	3.364	0.318	4.00	80	15.70
4 x 3	4.50	3.826	0.337	4.12	3.50	2.900	0.300	3.88	80	15.40
4 x 2 ½	4.50	3.826	0.337	4.12	2.88	2.323	0.276	3.75	80	15.10
4 x 2	4.50	3.826	0.337	4.12	2.38	1.939	0.218	3.50	80	15.10
4 x 1 ½	4.50	3.826	0.337	4.12	1.90	1.500	0.200	3.38	80	15.00
5 x 4	5.56	4.813	0.375	4.88	4.50	3.826	0.337	4.62	80	25.40
5 x 3 ½	5.56	4.813	0.375	4.88	4.00	3.364	0.318	4.50	80	24.80
5 x 3	5.56	4.813	0.375	4.88	3.50	2.900	0.300	4.38	80	24.20
5 x 2 ½	5.56	4.813	0.375	4.88	2.88	2.323	0.276	4.25	80	23.90
5 x 2	5.56	4.813	0.375	4.88	2.38	1.939	0.218	4.12	80	23.60
6 x 5	6.62	5.761	0.432	5.62	5.56	4.813	0.375	5.38	80	39.50
6 x 4	6.62	5.761	0.432	5.62	4.50	3.826	0.337	5.12	80	39.30
6 x 3 ½	6.62	5.761	0.432	5.62	4.00	3.364	0.318	5.00	80	38.80
6 x 3	6.62	5.761	0.432	5.62	3.50	2.900	0.300	4.88	80	38.60
6 x 2 ½	6.62	5.761	0.432	5.62	2.88	2.323	0.276	4.75	80	38.20
6 x 2	6.62	5.761	0.432	5.62	2.38	1.939	0.218	4.75	80	37.40
8 x 6	8.62	7.625	0.500	7.00	6.62	5.761	0.432	6.62	80	70.20
8 x 5	8.62	7.625	0.500	7.00	5.56	4.813	0.375	6.38	80	69.40
8 x 4	8.62	7.625	0.500	7.00	4.50	3.826	0.337	6.12	80	69.20
8 x 3 ½	8.62	7.625	0.500	7.00	4.00	3.364	0.318	6.00	80	68.60
8 x 3	8.62	7.625	0.500	7.00	3.50	2.900	0.300	6.00	80	68.30
10 x 8	10.75	9.750	0.500	8.50	8.62	7.620	0.500	8.00	-	107.00
10 x 6	10.75	9.750	0.500	8.50	6.62	5.761	0.432	7.62	-	104.00
10 x 5	10.75	9.750	0.500	8.50	5.56	4.813	0.375	7.50	-	103.00
10 x 4	10.75	9.750	0.500	8.50	4.50	3.826	0.337	7.25	-	101.00
10 x 3	10.75	9.750	0.500	8.50	3.50	2.900	0.300	7.25	-	99.00
12 x 10	12.75	11.750	0.500	10.00	10.75	9.750	0.500	9.50	-	165.00
12 x 8	12.75	11.750	0.500	10.00	8.62	7.625	0.500	9.00	-	156.00
12 x 6	12.75	11.750	0.500	10.00	6.62	5.761	0.432	8.62	-	151.00
12 x 5	12.75	11.750	0.500	10.00	5.56	4.813	0.375	8.50	-	149.00
12 x 4	12.75	11.750	0.500	10.00	4.50	3.826	0.337	8.50	-	148.00
14 x 12	14.00	13.000	0.500	11.00	12.75	11.750	0.500	10.62	-	210.00
14 x 10	14.00	13.000	0.500	11.00	10.75	9.750	0.500	10.12	-	203.00
14 x 8	14.00	13.000	0.500	11.00	8.62	7.625	0.500	9.75	-	200.00
14 x 6	14.00	13.000	0.500	11.00	6.62	5.761	0.432	9.38	-	196.00
16 x 14	16.00	15.000	0.500	12.00	14.00	13.000	0.500	12.00	-	268.00
16 x 12	16.00	15.000	0.500	12.00	12.75	11.750	0.500	11.62	-	261.00
16 x 10	16.00	15.000	0.500	12.00	10.75	9.750	0.500	11.12	-	250.00
16 x 8	16.00	15.000	0.500	12.00	8.62	7.625	0.500	10.75	-	240.00
16 x 6	16.00	15.000	0.500	12.00	6.62	5.761	0.432	10.38	-	235.00

FITTINGS T RED

Project Name: \_\_\_\_\_

Job #: \_\_\_\_\_

PIPE SIZE	DIMENSIONS OF RUN				DIMENSIONS OF BRANCH				PIPE SCHEDULE (XS)	APPROX WEIGHT
	OUTSIDE DIAMETER (O.D.)	INSIDE DIAMETER (I.D.)	WALL THICKNESS (W)	CENTER TO END (C)	OUTSIDE DIAMETER (O.D.)	INSIDE DIAMETER (I.D.)	WALL THICKNESS (W)	CENTER TO END (C)		
18 x 16	18.00	17.000	0.500	13.50	16.00	15.000	0.500	13.00	-	348.00
18 x 14	18.00	17.000	0.500	13.50	14.00	13.000	0.500	13.00	-	335.00
18 x 12	18.00	17.000	0.500	13.50	12.75	11.750	0.500	12.62	-	328.00
18 x 10	18.00	17.000	0.500	13.50	10.75	9.750	0.500	12.12	-	308.00
18 x 8	18.00	17.000	0.500	13.50	8.62	7.625	0.500	11.75	-	300.00
20 x 18	20.00	19.000	0.500	15.00	18.00	17.000	0.500	14.50	-	445.00
20 x 16	20.00	19.000	0.500	15.00	16.00	15.000	0.500	14.00	-	427.00
20 x 14	20.00	19.000	0.500	15.00	14.00	13.000	0.500	14.00	-	412.00
20 x 12	20.00	19.000	0.500	15.00	12.75	11.750	0.500	13.62	-	397.00
20 x 10	20.00	19.000	0.500	15.00	10.75	9.750	0.500	13.12	-	384.00
20 x 8	20.00	19.000	0.500	15.00	8.62	7.625	0.500	12.75	-	375.00
24 x 20	24.00	23.000	0.500	17.00	20.00	19.000	0.500	17.00	-	610.00
24 x 18	24.00	23.000	0.500	17.00	18.00	17.000	0.500	16.50	-	588.00
24 x 16	24.00	23.000	0.500	17.00	16.00	15.000	0.500	16.00	-	578.00
24 x 14	24.00	23.000	0.500	17.00	14.00	13.000	0.500	16.00	-	565.00
24 x 12	24.00	23.000	0.500	17.00	12.75	11.750	0.500	15.62	-	558.00
24 x 10	24.00	23.000	0.500	17.00	10.75	9.750	0.500	15.12	-	550.00
30 x 24	30.00	29.000	0.500	22.00	24.00	23.000	0.500	21.00	-	994.00
30 x 20	30.00	29.000	0.500	22.00	20.00	19.000	0.500	20.00	-	945.00
30 x 18	30.00	29.000	0.500	22.00	18.00	17.000	0.500	19.50	-	920.00
30 x 16	30.00	29.000	0.500	22.00	16.00	15.000	0.500	19.00	-	900.00
36 x 30	36.00	35.000	0.500	26.50	30.00	29.000	0.500	25.00	-	1510.00
36 x 24	36.00	35.000	0.500	26.50	24.00	23.000	0.500	24.00	-	1415.00
36 x 20	36.00	35.000	0.500	26.50	20.00	19.000	0.500	23.00	-	1345.00
36 x 18	36.00	35.000	0.500	26.50	18.00	17.000	0.500	22.50	-	1321.00
42 x 36	42.00	41.000	0.500	30.00	36.00	35.000	0.500	28.00	-	1709.00
42 x 30	42.00	41.000	0.500	30.00	30.00	29.000	0.500	28.00	-	1629.00
42 x 24	42.00	41.000	0.500	30.00	24.00	23.000	0.500	26.00	-	1550.00
42 x 20	42.00	41.000	0.500	30.00	20.00	19.000	0.500	26.00	-	1500.00
48 x 42	48.00	47.000	0.500	35.00	42.00	41.000	0.500	32.00	-	2207.00
48 x 36	48.00	47.000	0.500	35.00	36.00	35.000	0.500	31.00	-	2127.00
48 x 30	48.00	47.000	0.500	35.00	30.00	29.000	0.500	30.00	-	2048.00
48 x 24	48.00	47.000	0.500	35.00	24.00	23.000	0.500	29.00	-	1980.00

FITTINGS T RED

Project Name: \_\_\_\_\_  
 Job #: \_\_\_\_\_

**REDUCING TEES**  
 ASME B16.9 & ASTM A234 WPB

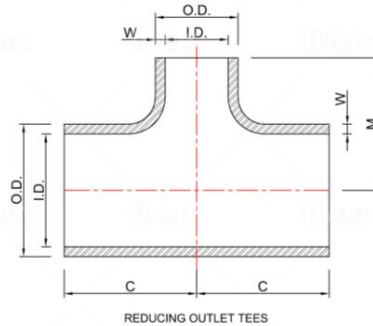

Source:  Import  Domestic  Approved

**DIMENSIONS**

UOM: Inches/LBS

PIPE SIZE	DIMENSIONS OF RUN				DIMENSIONS OF BRANCH				PIPE SCHEDULE (40)	APPROX WEIGHT
	OUTSIDE DIAMETER (O.D.)	INSIDE DIAMETER (I.D.)	WALL THICKNESS (W)	CENTER TO END (C)	OUTSIDE DIAMETER (O.D.)	INSIDE DIAMETER (I.D.)	WALL THICKNESS (W)	CENTER TO END (C)		
FOR DIMENSION SPECIFICATIONS ½" THROUGH 10", REFER TO SCHEDULE STD										
12 x 10	12.75	11.938	0.406	10.00	10.75	10.020	0.365	9.50	40	153.75
12 x 8	12.75	11.938	0.406	10.00	8.62	7.976	0.322	9.00	40	150.00
12 x 6	12.75	11.938	0.406	10.00	6.62	6.060	0.280	8.62	40	147.50
12 x 5	12.75	11.938	0.406	10.00	5.56	5.044	0.258	8.50	40	146.25
12 x 4	12.75	11.938	0.406	10.00	4.50	4.026	0.237	8.50	40	140.00
14 x 12	14.00	13.124	0.438	11.00	12.75	11.938	0.406	10.62	40	188.75
14 x 10	14.00	13.124	0.438	11.00	10.75	10.020	0.365	10.12	40	185.00
14 x 8	14.00	13.124	0.438	11.00	8.62	7.976	0.322	9.75	40	182.50
14 x 6	14.00	13.124	0.438	11.00	6.62	6.060	0.280	9.38	40	181.25
16 x 14	16.00	15.000	0.500	12.00	14.00	13.124	0.438	12.00	40	276.25
16 x 12	16.00	15.000	0.500	12.00	12.75	11.938	0.406	11.62	40	266.25
16 x 10	16.00	15.000	0.500	12.00	10.75	10.020	0.365	11.12	40	246.25
16 x 8	16.00	15.000	0.500	12.00	8.62	7.976	0.322	10.75	40	237.50
16 x 6	16.00	15.000	0.500	12.00	6.62	6.060	0.280	10.38	40	225.00
18 x 16	18.00	16.876	0.562	13.50	16.00	15.000	0.500	13.00	40	327.50
18 x 14	18.00	16.876	0.562	13.50	14.00	13.124	0.438	13.00	40	310.00
18 x 12	18.00	16.876	0.562	13.50	12.75	11.938	0.406	12.62	40	301.25
18 x 10	18.00	16.876	0.562	13.50	10.75	10.020	0.365	12.12	40	286.25
18 x 8	18.00	16.876	0.562	13.50	8.62	7.976	0.322	11.75	40	270.00
20 x 18	20.00	18.812	0.594	15.00	18.00	16.876	0.562	14.50	40	440.00
20 x 16	20.00	18.812	0.594	15.00	16.00	15.000	0.500	14.00	40	423.75
20 x 14	20.00	18.812	0.594	15.00	14.00	13.124	0.438	14.00	40	408.75
20 x 12	20.00	18.812	0.594	15.00	12.75	11.938	0.406	13.62	40	393.75
20 x 10	20.00	18.812	0.594	15.00	10.75	10.020	0.365	13.12	40	381.25
20 x 8	20.00	18.812	0.594	15.00	8.62	7.976	0.322	12.75	40	366.25
24 x 20	24.00	22.624	0.688	17.00	20.00	18.812	0.594	17.00	40	625.00
24 x 18	24.00	22.624	0.688	17.00	18.00	16.876	0.562	16.50	40	608.75
24 x 16	24.00	22.624	0.688	17.00	16.00	15.000	0.500	16.00	40	593.75
24 x 14	24.00	22.624	0.688	17.00	14.00	13.124	0.438	16.00	40	581.25
24 x 12	24.00	22.624	0.688	17.00	12.75	11.938	0.406	15.62	40	562.50
24 x 10	24.00	22.624	0.688	17.00	10.75	10.020	0.365	15.12	40	558.75

FITTINGS T RED

Project Name: \_\_\_\_\_

Job #: \_\_\_\_\_

## REDUCING TEES

ASME B16.9 & ASTM A234 WPB

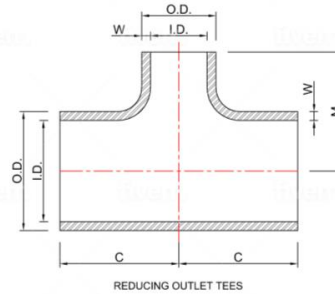

Source:  Import  Domestic  Approved

### DIMENSIONS

UOM: Inches/LBS

PIPE SIZE	DIMENSIONS OF RUN				DIMENSIONS OF BRANCH				PIPE SCHEDULE (80)	APPROX WEIGHT
	OUTSIDE DIAMETER (O.D.)	INSIDE DIAMETER (I.D.)	WALL THICKNESS (W)	CENTER TO END (C)	OUTSIDE DIAMETER (O.D.)	INSIDE DIAMETER (I.D.)	WALL THICKNESS (W)	CENTER TO END (C)		
FOR DIMENSION SPECIFICATIONS ½" THROUGH 8", REFER TO SCHEDULE XS										
10 x 8	10.75	9.562	0.594	8.50	8.62	7.620	0.500	8.00	80	151.38
10 x 6	10.75	9.562	0.594	8.50	6.62	5.756	0.432	7.62	80	150.33
10 x 5	10.75	9.562	0.594	8.50	5.56	4.810	0.375	7.50	80	144.38
10 x 4	10.75	9.562	0.594	8.50	4.50	3.826	0.337	7.25	80	143.50
10 x 3	10.75	9.562	0.594	8.50	3.50	2.900	0.300	7.25	80	142.00
12 x 10	12.75	11.374	0.688	10.00	10.75	9.562	0.594	9.50	80	215.25
12 x 8	12.75	11.374	0.688	10.00	8.62	7.620	0.500	9.00	80	210.00
12 x 6	12.75	11.374	0.688	10.00	6.62	5.756	0.432	8.62	80	206.50
12 x 5	12.75	11.374	0.688	10.00	5.56	4.810	0.375	8.50	80	204.75
12 x 4	12.75	11.374	0.688	10.00	4.50	3.826	0.337	8.50	80	196.00
14 x 12	14.00	12.500	0.750	11.00	12.75	11.374	0.688	10.62	80	264.25
14 x 10	14.00	12.500	0.750	11.00	10.75	9.562	0.594	10.12	80	259.00
14 x 8	14.00	12.500	0.750	11.00	8.62	7.620	0.500	9.75	80	255.50
14 x 6	14.00	12.500	0.750	11.00	6.62	5.756	0.432	9.38	80	253.75
16 x 14	16.00	14.312	0.844	12.00	14.00	12.500	0.750	12.00	80	386.75
16 x 12	16.00	14.312	0.844	12.00	12.75	11.374	0.688	11.62	80	372.75
16 x 10	16.00	14.312	0.844	12.00	10.75	9.562	0.594	11.12	80	344.75
16 x 8	16.00	14.312	0.844	12.00	8.62	7.620	0.500	10.75	80	332.50
16 x 6	16.00	14.312	0.844	12.00	6.62	5.756	0.432	10.38	80	315.00
18 x 16	18.00	16.124	0.938	13.50	16.00	14.312	0.844	13.00	80	458.50
18 x 14	18.00	16.124	0.938	13.50	14.00	12.500	0.750	13.00	80	434.00
18 x 12	18.00	16.124	0.938	13.50	12.75	11.374	0.688	12.62	80	421.75
18 x 10	18.00	16.124	0.938	13.50	10.75	9.562	0.594	12.12	80	400.75
18 x 8	18.00	16.124	0.938	13.50	8.62	7.620	0.500	11.75	80	378.00
20 x 18	20.00	17.938	1.031	15.00	18.00	16.124	0.938	14.50	80	616.00
20 x 16	20.00	17.938	1.031	15.00	16.00	14.312	0.844	14.00	80	593.25
20 x 14	20.00	17.938	1.031	15.00	14.00	12.500	0.750	14.00	80	572.25
20 x 12	20.00	17.938	1.031	15.00	12.75	11.374	0.688	13.62	80	551.25
20 x 10	20.00	17.938	1.031	15.00	10.75	9.562	0.594	13.12	80	533.75
20 x 8	20.00	17.938	1.031	15.00	8.62	7.620	0.500	12.75	80	512.75
24 x 20	24.00	21.562	1.219	17.00	20.00	17.938	1.031	17.00	80	875.00
24 x 18	24.00	21.562	1.219	17.00	18.00	16.124	0.938	16.50	80	852.25
24 x 16	24.00	21.562	1.219	17.00	16.00	14.312	0.844	16.00	80	831.25
24 x 14	24.00	21.562	1.219	17.00	14.00	12.500	0.750	16.00	80	813.75
24 x 12	24.00	21.562	1.219	17.00	12.75	11.374	0.688	15.62	80	787.50
24 x 10	24.00	21.562	1.219	17.00	10.75	9.562	0.594	15.12	80	782.25

FITTINGS T RED

Project Name: \_\_\_\_\_  
 Job #: \_\_\_\_\_

## REDUCING TEES

### ASME B16.9 & ASTM A234 WPB

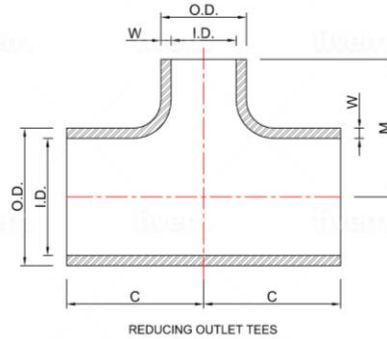

Source:  Import  Domestic  Approved

## DIMENSIONS

UOM: Inches/LBS

PIPE SIZE	DIMENSIONS OF RUN				DIMENSIONS OF BRANCH				PIPE SCHEDULE (160)	APPROX WEIGHT
	OUTSIDE DIAMETER (O.D.)	INSIDE DIAMETER (I.D.)	WALL THICKNESS (W)	CENTER TO END (C)	OUTSIDE DIAMETER (O.D.)	INSIDE DIAMETER (I.D.)	WALL THICKNESS (W)	CENTER TO END (C)		
¾ x ½	1.05	0.612	0.219	1.12	0.84	0.464	0.188	1.12	160	0.66
1 x ¾	1.32	0.820	0.250	1.50	1.05	0.612	0.219	1.50	160	1.37
1 x ½	1.32	0.820	0.250	1.50	0.84	0.464	0.188	1.50	160	1.29
1 ¼ x 1	1.66	1.160	0.250	1.88	1.32	0.820	0.250	1.88	160	2.24
1 ¼ x ¾	1.66	1.160	0.250	1.88	1.05	0.612	0.219	1.88	160	2.24
1 ¼ x ½	1.66	1.160	0.250	1.88	0.84	0.464	0.188	1.88	160	2.24
1 ½ x 1 ¼	1.90	1.338	0.281	2.25	1.66	1.160	0.250	2.25	160	3.36
1 ½ x 1	1.90	1.338	0.281	2.25	1.32	0.820	0.250	2.25	160	3.22
1 ½ x ¾	1.90	1.338	0.281	2.25	1.05	0.612	0.219	2.25	160	3.08
1 ½ x ½	1.90	1.338	0.281	2.25	0.84	0.464	0.188	2.25	160	3.08
2 x 1 ½	2.38	1.692	0.344	2.50	1.90	1.338	0.281	2.38	160	5.32
2 x 1 ¼	2.38	1.692	0.344	2.50	1.66	1.160	0.250	2.25	160	5.18
2 x 1	2.38	1.692	0.344	2.50	1.32	0.820	0.250	2.00	160	4.90
2 x ¾	2.38	1.692	0.344	2.50	1.05	0.612	0.219	1.75	160	4.90
2 ½ x 2	2.88	2.130	0.375	3.00	2.38	1.692	0.344	2.75	160	8.82
2 ½ x 1 ½	2.88	2.130	0.375	3.00	1.90	1.338	0.281	2.62	160	8.68
2 ½ x 1 ¼	2.88	2.130	0.375	3.00	1.66	1.160	0.250	2.50	160	8.40
2 ½ x 1	2.88	2.130	0.375	3.00	1.32	0.820	0.250	2.25	160	8.12
3 x 2 ½	3.50	2.624	0.438	3.38	2.88	2.130	0.375	3.25	160	12.32
3 x 2	3.50	2.624	0.438	3.38	2.38	1.692	0.344	3.00	160	12.04
3 x 1 ½	3.50	2.624	0.438	3.38	1.90	1.338	0.281	2.88	160	11.34
3 x 1 ¼	3.50	2.624	0.438	3.38	1.66	1.160	0.250	2.75	160	11.20
3 x 1	3.50	2.624	0.438	3.38	1.32	0.820	0.250	2.62	160	11.20

FITTINGS T RED

Project Name: \_\_\_\_\_

Job #: \_\_\_\_\_

FITTINGS T RED

PIPE SIZE	DIMENSIONS OF RUN				DIMENSIONS OF BRANCH				PIPE SCHEDULE (160)	APPROX WEIGHT
	OUTSIDE DIAMETER (O.D.)	INSIDE DIAMETER (I.D.)	WALL THICKNESS (W)	CENTER TO END (C)	OUTSIDE DIAMETER (O.D.)	INSIDE DIAMETER (I.D.)	WALL THICKNESS (W)	CENTER TO END (C)		
4 x 3	4.50	3.438	0.531	4.12	3.50	2.624	0.438	3.88	160	21.56
4 x 2 ½	4.50	3.438	0.531	4.12	2.88	2.130	0.375	3.75	160	21.14
4 x 2	4.50	3.438	0.531	4.12	2.38	1.692	0.344	3.50	160	21.14
4 x 1 ½	4.50	3.438	0.531	4.12	1.90	1.338	0.281	3.38	160	21.00
5 x 4	5.56	4.310	0.625	4.88	4.50	3.438	0.531	4.62	160	35.56
5 x 3	5.56	4.310	0.625	4.88	3.50	2.624	0.438	4.38	160	33.88
5 x 2 ½	5.56	4.310	0.625	4.88	2.88	2.130	0.375	4.25	160	33.46
5 x 2	5.56	4.310	0.625	4.88	2.38	1.692	0.344	4.12	160	33.04
6 x 5	6.62	5.182	0.719	5.62	5.56	4.310	0.625	5.38	160	55.30
6 x 4	6.62	5.182	0.719	5.62	4.50	3.438	0.531	5.12	160	55.02
6 x 3	6.62	5.182	0.719	5.62	3.50	2.624	0.438	4.88	160	54.04
6 x 2 ½	6.62	5.182	0.719	5.62	2.88	2.130	0.375	4.75	160	53.48
6 x 2	6.62	5.182	0.719	5.62	2.38	1.692	0.344	4.75	160	52.36
8 x 6	8.62	6.808	0.906	7.00	6.62	5.182	0.719	6.62	160	98.28
8 x 5	8.62	6.808	0.906	7.00	5.56	4.310	0.625	6.38	160	97.16
8 x 4	8.62	6.808	0.906	7.00	4.50	3.438	0.531	6.12	160	96.88
8 x 3	8.62	6.808	0.906	7.00	3.50	2.624	0.438	6.00	160	95.62
10 x 8	10.75	8.500	1.125	8.50	8.62	6.808	0.906	8.00	160	149.80
10 x 6	10.75	8.500	1.125	8.50	6.62	5.182	0.719	7.62	160	145.60
10 x 5	10.75	8.500	1.125	8.50	5.56	4.310	0.625	7.50	160	144.20
10 x 4	10.75	8.500	1.125	8.50	4.50	3.438	0.531	7.25	160	141.40
10 x 3	10.75	8.500	1.125	8.50	3.50	2.624	0.438	7.25	160	140.00
12 x 10	12.75	10.126	1.312	10.00	10.75	8.500	1.125	9.50	160	231.00
12 x 8	12.75	10.126	1.312	10.00	8.62	6.808	0.906	9.00	160	218.40
12 x 6	12.75	10.126	1.312	10.00	6.62	5.182	0.719	8.62	160	211.40
12 x 5	12.75	10.126	1.312	10.00	5.56	4.310	0.625	8.50	160	208.60
12 x 4	12.75	10.126	1.312	10.00	4.50	3.438	0.531	8.50	160	207.20
14 x 12	14.00	11.188	1.406	11.00	12.75	10.126	1.312	10.62	160	294.00
14 x 10	14.00	11.188	1.406	11.00	10.75	8.500	1.125	10.12	160	284.20
14 x 8	14.00	11.188	1.406	11.00	8.62	6.808	0.906	9.75	160	280.00
14 x 6	14.00	11.188	1.406	11.00	6.62	5.182	0.719	9.38	160	274.40
16 x 14	16.00	12.812	1.594	12.00	14.00	11.188	1.406	12.00	160	375.20
16 x 12	16.00	12.812	1.594	12.00	12.75	10.126	1.312	11.62	160	365.40
16 x 10	16.00	12.812	1.594	12.00	10.75	8.500	1.125	11.12	160	350.00
16 x 8	16.00	12.812	1.594	12.00	8.62	6.808	0.906	10.75	160	336.00
16 x 6	16.00	12.812	1.594	12.00	6.62	5.182	0.719	10.38	160	329.00
18 x 16	18.00	14.438	1.781	13.50	16.00	12.812	1.594	13.00	160	487.20
18 x 14	18.00	14.438	1.781	13.50	14.00	11.188	1.406	13.00	160	469.00
18 x 12	18.00	14.438	1.781	13.50	12.75	10.126	1.312	12.62	160	459.20
18 x 10	18.00	14.438	1.781	13.50	10.75	8.500	1.125	12.12	160	431.20
18 x 8	18.00	14.438	1.781	13.50	8.62	6.808	0.906	11.75	160	420.00



Project Name: \_\_\_\_\_

Job #: \_\_\_\_\_

PIPE SIZE	DIMENSIONS OF RUN				DIMENSIONS OF BRANCH				PIPE SCHEDULE (160)	APPROX WEIGHT
	OUTSIDE DIAMETER (O.D.)	INSIDE DIAMETER (I.D.)	WALL THICKNESS (W)	CENTER TO END (C)	OUTSIDE DIAMETER (O.D.)	INSIDE DIAMETER (I.D.)	WALL THICKNESS (W)	CENTER TO END (C)		
20 x 18	20.00	16.062	1.969	15.00	18.00	14.438	1.781	14.50	160	623.00
20 x 16	20.00	16.062	1.969	15.00	16.00	12.812	1.594	14.00	160	597.80
20 x 14	20.00	16.062	1.969	15.00	14.00	11.188	1.406	14.00	160	576.80
20 x 12	20.00	16.062	1.969	15.00	12.75	10.126	1.312	13.62	160	555.80
20 x 10	20.00	16.062	1.969	15.00	10.75	8.500	1.125	13.12	160	537.60
20 x 8	20.00	16.062	1.969	15.00	8.62	6.808	0.906	12.75	160	525.00
24 x 20	24.00	19.312	2.344	17.00	20.00	16.062	1.969	17.00	160	854.00
24 x 18	24.00	19.312	2.344	17.00	18.00	14.438	1.781	16.50	160	823.20
24 x 16	24.00	19.312	2.344	17.00	16.00	12.812	1.594	16.00	160	809.20
24 x 14	24.00	19.312	2.344	17.00	14.00	11.188	1.406	16.00	160	791.00
24 x 12	24.00	19.312	2.344	17.00	12.75	10.126	1.312	15.62	160	781.20
24 x 10	24.00	19.312	2.344	17.00	10.75	8.500	1.125	15.12	160	770.00

FITTINGS T RED

acecarbonsteel

Project Name: \_\_\_\_\_

Job #: \_\_\_\_\_

## REDUCING TEES

### ASME B16.9 & ASTM A234 WPB

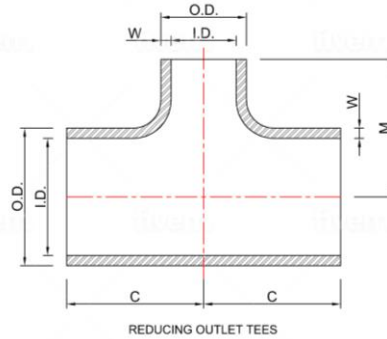

Source:  Import  Domestic  Approved

## DIMENSIONS

UOM: Inches/LBS

PIPE SIZE	DIMENSIONS OF RUN				DIMENSIONS OF BRANCH				PIPE SCHEDULE (XXS)	APPROX WEIGHT
	OUTSIDE DIAMETER (O.D.)	INSIDE DIAMETER (I.D.)	WALL THICKNESS (W)	CENTER TO END (C)	OUTSIDE DIAMETER (O.D.)	INSIDE DIAMETER (I.D.)	WALL THICKNESS (W)	CENTER TO END (C)		
¾ x ½	1.05	0.434	0.308	1.12	0.84	0.252	0.294	1.12	-	0.74
1 x ¾	1.32	0.604	0.358	1.50	1.05	0.434	0.308	1.50	-	1.54
1 x ½	1.32	0.604	0.358	1.50	0.84	0.252	0.294	1.50	-	1.45
1 ¼ x 1	1.66	0.896	0.382	1.88	1.32	0.604	0.358	1.88	-	2.52
1 ¼ x ¾	1.66	0.896	0.382	1.88	1.05	0.434	0.308	1.88	-	2.52
1 ¼ x ½	1.66	0.896	0.382	1.88	0.84	0.252	0.294	1.88	-	2.52
1 ½ x 1 ¼	1.90	1.100	0.400	2.25	1.66	0.896	0.382	2.25	-	3.78
1 ½ x 1	1.90	1.100	0.400	2.25	1.32	0.604	0.358	2.25	-	3.62
1 ½ x ¾	1.90	1.100	0.400	2.25	1.05	0.434	0.308	2.25	-	3.47
1 ½ x ½	1.90	1.100	0.400	2.25	0.84	0.252	0.294	2.25	-	3.47
2 x 1 ½	2.38	1.508	0.436	2.50	1.90	1.100	0.400	2.38	-	5.99
2 x 1 ¼	2.38	1.508	0.436	2.50	1.66	0.896	0.382	2.25	-	5.83
2 x 1	2.38	1.508	0.436	2.50	1.32	0.604	0.358	2.00	-	5.51
2 x ¾	2.38	1.508	0.436	2.50	1.05	0.434	0.552	1.75	-	5.51
2 ½ x 2	2.88	1.776	0.552	3.00	2.38	1.508	0.436	2.75	-	9.92
2 ½ x 1 ½	2.88	1.776	0.552	3.00	1.90	1.100	0.400	2.62	-	9.77
2 ½ x 1 ¼	2.88	1.776	0.552	3.00	1.66	0.896	0.382	2.50	-	9.45
2 ½ x 1	2.88	1.776	0.552	3.00	1.32	0.604	0.358	2.25	-	9.14
3 x 2 ½	3.50	2.300	0.600	3.38	2.88	1.776	0.600	3.25	-	13.86
3 x 2	3.50	2.300	0.600	3.38	2.38	1.508	0.552	3.00	-	13.55
3 x 1 ½	3.50	2.300	0.600	3.38	1.90	1.100	0.436	2.88	-	12.76
3 x 1 ¼	3.50	2.300	0.600	3.38	1.66	0.896	0.400	2.75	-	12.60
3 x 1	3.50	2.300	0.600	3.38	1.32	0.604	0.674	2.62	-	12.60

FITTINGS T RED



Project Name: \_\_\_\_\_

Job #: \_\_\_\_\_

PIPE SIZE	DIMENSIONS OF RUN				DIMENSIONS OF BRANCH				PIPE SCHEDULE (XXS)	APPROX WEIGHT
	OUTSIDE DIAMETER (O.D.)	INSIDE DIAMETER (I.D.)	WALL THICKNESS (W)	CENTER TO END (C)	OUTSIDE DIAMETER (O.D.)	INSIDE DIAMETER (I.D.)	WALL THICKNESS (W)	CENTER TO END (C)		
4 x 3	4.50	3.152	0.674	4.12	3.50	2.300	0.600	3.88	-	24.26
4 x 2 ½	4.50	3.152	0.674	4.12	2.88	1.776	0.552	3.75	-	23.78
4 x 2	4.50	3.152	0.674	4.12	2.38	1.508	0.436	3.50	-	23.78
4 x 1 ½	4.50	3.152	0.674	4.12	1.90	1.100	0.400	3.38	-	23.63
5 x 4	5.56	4.060	0.750	4.88	4.50	3.152	0.674	4.62	-	40.01
5 x 3	5.56	4.060	0.750	4.88	3.50	2.300	0.600	4.38	-	38.21
5 x 2 ½	5.56	4.060	0.750	4.88	2.88	1.776	0.552	4.25	-	37.64
5 x 2	5.56	4.060	0.750	4.88	2.38	1.508	0.436	4.12	-	37.17
6 x 5	6.62	4.892	0.864	5.62	5.56	4.060	0.750	5.38	-	62.21
6 x 4	6.62	4.892	0.864	5.62	4.50	3.152	0.674	5.12	-	61.90
6 x 3	6.62	4.892	0.864	5.62	3.50	2.300	0.600	4.88	-	60.80
6 x 2 ½	6.62	4.892	0.864	5.62	2.88	1.776	0.552	4.75	-	60.17
6 x 2	6.62	4.892	0.864	5.62	2.38	1.508	0.436	4.75	-	58.91
8 x 6	8.62	6.870	0.875	7.00	6.62	4.892	0.864	6.62	-	110.57
8 x 5	8.62	6.870	0.875	7.00	5.56	4.060	0.750	6.38	-	109.31
8 x 4	8.62	6.870	0.875	7.00	4.50	3.152	0.674	6.12	-	108.99
8 x 3	8.62	6.870	0.875	7.00	3.50	2.300	0.600	6.00	-	107.57
10 x 8	10.75	8.750	1.000	8.50	8.62	6.870	0.875	8.00	-	168.53
10 x 6	10.75	8.750	1.000	8.50	6.62	4.892	0.864	7.62	-	163.80
10 x 5	10.75	8.750	1.000	8.50	5.56	4.060	0.750	7.50	-	162.23
10 x 4	10.75	8.750	1.000	8.50	4.50	3.152	0.674	7.25	-	159.80
10 x 3	10.75	8.750	1.000	8.50	3.50	2.300	0.600	7.25	-	158.00
12 x 10	12.75	10.750	1.000	10.00	10.75	8.750	1.000	9.50	-	259.88
12 x 8	12.75	10.750	1.000	10.00	8.62	6.870	0.875	9.00	-	254.70
12 x 6	12.75	10.750	1.000	10.00	6.62	4.892	0.864	8.62	-	237.83
12 x 5	12.75	10.750	1.000	10.00	5.56	4.060	0.750	8.50	-	234.68
12 x 4	12.75	10.750	1.000	10.00	4.50	3.152	0.674	8.50	-	233.10

FITTINGS T RED

Project Name: \_\_\_\_\_  
 Job #: \_\_\_\_\_

# TEES

ASME B16.9 & ASTM A234 WPB

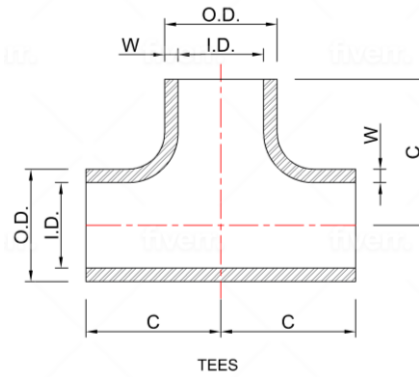

Source:  Import  Domestic  Approved

## DIMENSIONS

UOM: Inches/LBS

NOMINAL PIPE SIZE	OUTSIDE DIAMETER (O.D.)	CENTER TO CENTER	CENTER TO END	INSIDE DIAMETER (I.D.)	WALL THICKNESS (W)	PIPE SCHEDULE (STD)	APPROX WEIGHT
1/2	0.84	1.00	1.00	0.622	0.109	40	0.35
3/4	1.05	1.12	1.12	0.824	0.113	40	0.50
1	1.32	1.50	1.50	1.049	0.133	40	0.75
1 1/4	1.66	1.88	1.88	1.380	0.140	40	1.30
1 1/2	1.90	2.25	2.25	1.610	0.145	40	1.90
2	2.38	2.50	2.50	2.067	0.154	40	3.20
2 1/2	2.88	3.00	3.00	2.469	0.203	40	5.80
3	3.50	3.38	3.38	3.068	0.216	40	7.20
3 1/2	4.00	3.75	3.75	3.548	0.226	40	9.50
4	4.50	4.12	4.12	4.026	0.237	40	12.70
5	5.56	4.88	4.88	5.047	0.258	40	20.80
6	6.62	5.62	5.62	6.065	0.280	40	33.10
8	8.62	7.00	7.00	7.981	0.322	40	56.50
10	10.75	8.50	8.50	10.020	0.365	40	90.90
12	12.75	10.00	10.00	12.000	0.375	-	136.00
14	14.00	11.00	11.00	13.250	0.375	30	162.00
16	16.00	12.00	12.00	15.250	0.375	30	206.00
18	18.00	13.50	13.50	17.250	0.375	-	272.00
20	20.00	15.00	15.00	19.250	0.375	20	350.00
24	24.00	17.00	17.00	23.250	0.375	20	508.00
30	30.00	22.00	22.00	29.250	0.375	-	835.00
36	36.00	26.50	26.50	35.250	0.375	-	1294.00
42	42.00	30.00	30.00	41.250	0.375	-	1495.00
48	48.00	35.00	35.00	47.250	0.375	-	2300.00

FITTINGS THE

Project Name: \_\_\_\_\_

Job #: \_\_\_\_\_

# TEES

ASME B16.9 & ASTM A234 WPB

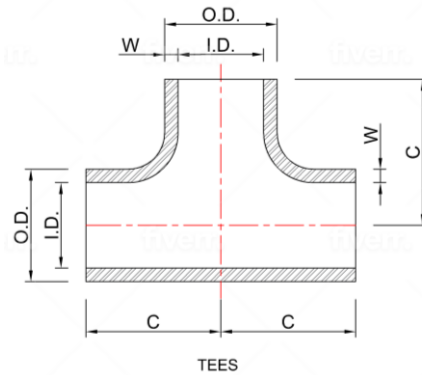

Source:  Import  Domestic  Approved

## DIMENSIONS

UOM: Inches/LBS

NOMINAL PIPE SIZE	OUTSIDE DIAMETER (O.D.)	CENTER TO CENTER	CENTER TO END	INSIDE DIAMETER (I.D.)	WALL THICKNESS (W)	PIPE SCHEDULE (XS)	APPROX WEIGHT
1/2	0.84	1.00	1.00	0.546	0.147	80	0.37
3/4	1.05	1.12	1.12	0.742	0.154	80	0.58
1	1.32	1.50	1.50	0.957	0.179	80	0.87
1 1/4	1.66	1.88	1.88	1.278	0.191	80	1.60
1 1/2	1.90	2.25	2.25	1.500	0.200	80	2.30
2	2.38	2.50	2.50	1.939	0.218	80	3.90
2 1/2	2.88	3.00	3.00	2.323	0.276	80	6.50
3	3.50	3.38	3.38	2.900	0.300	80	9.00
3 1/2	4.00	3.75	3.75	3.364	0.318	80	12.20
4	4.50	4.12	4.12	3.826	0.337	80	16.20
5	5.56	4.88	4.88	4.813	0.375	80	26.60
6	6.62	5.62	5.62	5.761	0.432	80	41.80
8	8.62	7.00	7.00	7.625	0.500	80	76.20
10	10.75	8.50	8.50	9.750	0.500	60	115.00
12	12.75	10.00	10.00	11.750	0.500	-	169.00
14	14.00	11.00	11.00	13.000	0.500	-	237.00
16	16.00	12.00	12.00	15.000	0.500	40	284.00
18	18.00	13.50	13.50	17.000	0.500	-	353.00
20	20.00	15.00	15.00	19.000	0.500	30	442.00
24	24.00	17.00	17.00	23.000	0.500	-	625.00
30	30.00	22.00	22.00	29.000	0.500	20	1065.00
36	36.00	26.50	26.50	35.000	0.500	20	1610.00
42	42.00	30.00	30.00	41.000	0.500	-	1788.00
48	48.00	35.00	35.00	47.000	0.500	-	2300.00

FITTINGS TEE

Project Name: \_\_\_\_\_

Job #: \_\_\_\_\_

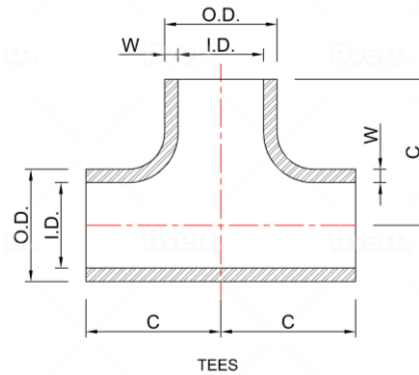
**TEES****ASME B16.9 & ASTM A234 WPB**Source:  Import  Domestic  Approved**DIMENSIONS**

UOM: Inches/LBS

NOMINAL PIPE SIZE	OUTSIDE DIAMETER (O.D.)	CENTER TO CENTER	CENTER TO END	INSIDE DIAMETER (I.D.)	WALL THICKNESS (W)	PIPE SCHEDULE (40)	APPROX WEIGHT
1/2	0.84	1.00	1.00	0.622	0.109	40	0.35
3/4	1.05	1.12	1.12	0.824	0.113	40	0.50
1	1.32	1.50	1.50	1.054	0.133	40	0.75
1 1/4	1.66	1.88	1.88	1.380	0.140	40	1.30
1 1/2	1.90	2.25	2.25	1.610	0.145	40	1.90
2	2.38	2.50	2.50	2.072	0.154	40	3.20
2 1/2	2.88	3.00	3.00	2.474	0.203	40	5.80
3	3.50	3.38	3.38	3.068	0.216	40	7.20
3 1/2	4.00	3.75	3.75	3.548	0.226	40	8.50
4	4.50	4.12	4.12	4.026	0.237	40	9.50
5	5.56	4.88	4.88	5.044	0.258	40	12.70
6	6.62	5.62	5.62	6.060	0.280	40	20.80
8	8.62	7.00	7.00	7.976	0.322	40	33.10
10	10.75	8.50	8.50	10.020	0.365	40	56.50
12	12.75	10.00	10.00	11.938	0.406	40	90.90
14	14.00	11.00	11.00	13.124	0.438	40	165.00
16	16.00	12.00	12.00	15.000	0.500	40	210.00
18	18.00	13.50	13.50	16.876	0.562	40	275.00
20	20.00	15.00	15.00	18.812	0.594	40	355.00
24	24.00	17.00	17.00	22.624	0.688	40	510.00

Project Name: \_\_\_\_\_

Job #: \_\_\_\_\_

## TEES

ASME B16.9 & ASTM A234 WPB

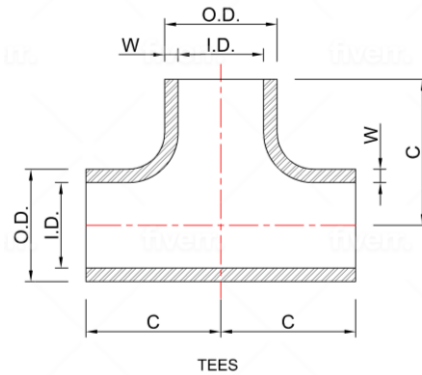

Source:  Import  Domestic  Approved

## DIMENSIONS

UOM: Inches/LBS

NOMINAL PIPE SIZE	OUTSIDE DIAMETER (O.D.)	CENTER TO CENTER	CENTER TO END	INSIDE DIAMETER (I.D.)	WALL THICKNESS (W)	PIPE SCHEDULE (80)	APPROX WEIGHT
1/2	0.84	1.00	1.00	0.546	0.147	80	0.37
3/4	1.05	1.12	1.12	0.742	0.154	80	0.58
1	1.32	1.50	1.50	0.957	0.179	80	0.87
1 1/4	1.66	1.88	1.88	1.278	0.191	80	1.60
1 1/2	1.90	2.25	2.25	1.500	0.200	80	2.30
2	2.38	2.50	2.50	1.939	0.218	80	3.90
2 1/2	2.88	3.00	3.00	2.323	0.276	80	6.50
3	3.50	3.38	3.38	2.900	0.300	80	9.00
3 1/2	4.00	3.75	3.75	3.364	0.318	80	12.20
4	4.50	4.12	4.12	3.826	0.337	80	16.20
5	5.56	4.88	4.88	4.810	0.375	80	26.60
6	6.62	5.62	5.62	5.756	0.432	80	41.80
8	8.62	7.00	7.00	7.620	0.500	80	76.20
10	10.75	8.50	8.50	9.562	0.594	80	120.00
12	12.75	10.00	10.00	11.374	0.688	80	175.00
14	14.00	11.00	11.00	12.500	0.750	80	240.00
16	16.00	12.00	12.00	14.312	0.844	80	290.00
18	18.00	13.50	13.50	16.124	0.938	80	360.00
20	20.00	15.00	15.00	17.938	1.031	80	450.00
24	24.00	17.00	17.00	21.562	1.219	80	630.00

FITTINGS TEE

Project Name: \_\_\_\_\_

Job #: \_\_\_\_\_

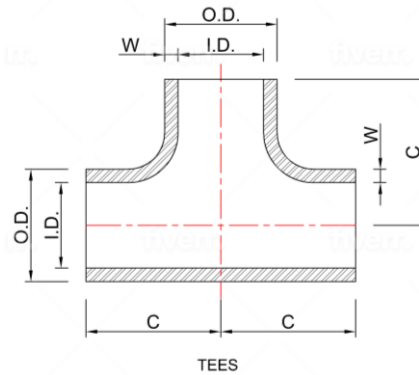
**TEES****ASME B16.9 & ASTM A234 WPB**Source:  Import  Domestic  Approved**DIMENSIONS**

UOM: Inches/LBS

NOMINAL PIPE SIZE	OUTSIDE DIAMETER (O.D.)	CENTER TO CENTER	CENTER TO END	INSIDE DIAMETER (I.D.)	WALL THICKNESS (W)	PIPE SCHEDULE (160)	APPROX WEIGHT
1/2	0.84	1.00	1.00	0.464	0.188	160	0.46
3/4	1.05	1.12	1.12	0.612	0.219	160	0.73
1	1.32	1.50	1.50	0.820	0.250	160	1.09
1 1/4	1.66	1.88	1.88	1.160	0.250	160	2.00
1 1/2	1.90	2.25	2.25	1.338	0.281	160	2.88
2	2.38	2.50	2.50	1.692	0.344	160	4.88
2 1/2	2.88	3.00	3.00	2.130	0.375	160	8.13
3	3.50	3.38	3.38	2.624	0.438	160	11.25
4	4.50	4.12	4.12	3.438	0.531	160	20.25
5	5.56	4.88	4.88	4.310	0.625	160	33.25
6	6.62	5.62	5.62	5.182	0.719	160	52.25
8	8.62	7.00	7.00	6.808	0.906	160	95.25
10	10.75	8.50	8.50	8.500	1.125	160	143.75
12	12.75	10.00	10.00	10.126	1.312	160	211.25
14	14.00	11.00	11.00	11.188	1.406	160	296.25
16	16.00	12.00	12.00	12.812	1.594	160	355.00
18	18.00	13.50	13.50	14.438	1.781	160	441.25
20	20.00	15.00	15.00	16.062	1.969	160	552.50
24	24.00	17.00	17.00	19.312	2.344	160	781.25

Project Name: \_\_\_\_\_

Job #: \_\_\_\_\_

# TEES

ASME B16.9 & ASTM A234 WPB

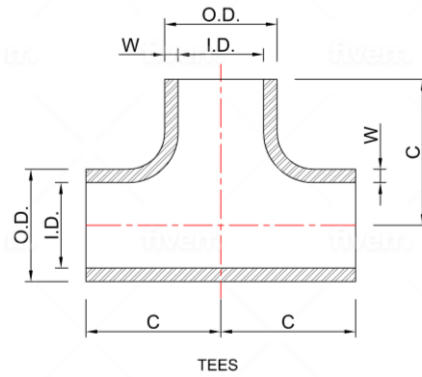

Source:  Import  Domestic  Approved

## DIMENSIONS

UOM: Inches/LBS

NOMINAL PIPE SIZE	OUTSIDE DIAMETER (O.D.)	CENTER TO CENTER	CENTER TO END	INSIDE DIAMETER (I.D.)	WALL THICKNESS (W)	PIPE SCHEDULE (XXS)	APPROX WEIGHT
1/2	0.84	1.00	1.00	0.252	0.294	-	0.51
3/4	1.05	1.12	1.12	0.434	0.308	-	0.80
1	1.32	1.50	1.50	0.604	0.358	-	1.20
1 1/4	1.66	1.88	1.88	0.896	0.382	-	2.20
1 1/2	1.90	2.25	2.25	1.100	0.400	-	3.16
2	2.38	2.50	2.50	1.508	0.436	-	5.36
2 1/2	2.88	3.00	3.00	1.776	0.552	-	8.94
3	3.50	3.38	3.38	2.300	0.600	-	12.38
4	4.50	4.12	4.12	3.152	0.674	-	22.28
5	5.56	4.88	4.88	4.060	0.750	-	36.58
6	6.62	5.62	5.62	4.892	0.864	-	57.48
8	8.62	7.00	7.00	6.870	0.875	-	104.78
10	10.75	8.50	8.50	8.750	1.000	140	158.13
12	12.75	10.00	10.00	10.750	1.000	120	232.38

FITTINGS TEE